

# Ordering Information

## F258-11 10 A2 C SU B 2T

- 规格:
1. 额定电压: 12V AC/DC
  2. 额定电流: 0.5A AC/DC
  3. 接触电阻:  $\leq 10m\Omega$
  4. 环境测试后(接触电阻):  $\leq 25m\Omega$
  5. 绝缘电阻:  $\geq 100M\Omega$
  6. 耐压值: 1000V AC/minute
  7. PIN针保持力: 15N
  8. 工作温度:  $-40^{\circ}C \sim +85^{\circ}C$
  9. 环保要求: RoHS 有卤

- 备注:
1. PIN针: 磷铜 镀镍 $40 \sim 80\mu\text{Min}$ 镀金:  $1.5\mu\text{Min}$
  2. 产品不可缺 端子、歪 PIN、长短 PIN、PIN孔破裂、电镀层氧化、胶体压伤等外观不良
  3. 未注公差尺寸允许偏差按《GB/T14486-2008注塑件尺寸公差》MT5-A级执行;
  4. 标有“XX”为 FAI测量尺寸
  5. 标记“\*”表示需要控制的重点尺寸
  6. “★”为 SPC 管控尺寸
  7. 治具编号: XXXX-XX-XX (其中XX代表不一样的工站, 每个工站的治具编号, 需要刻在相应的工站治具上, 编号原则以及刻字标准见文件《产品料号&模具编码原则》)
  8. 盐雾: 48H

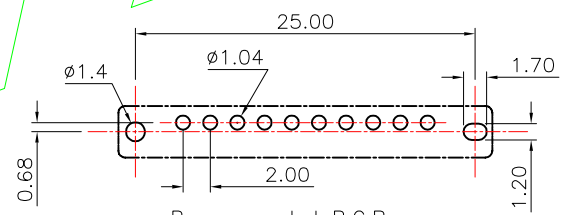
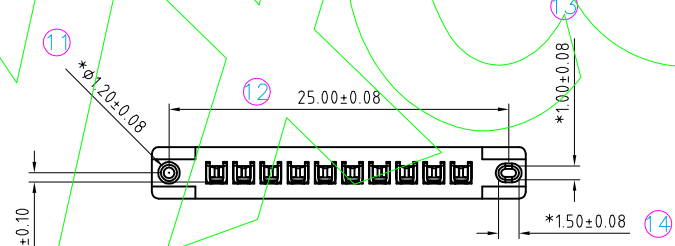
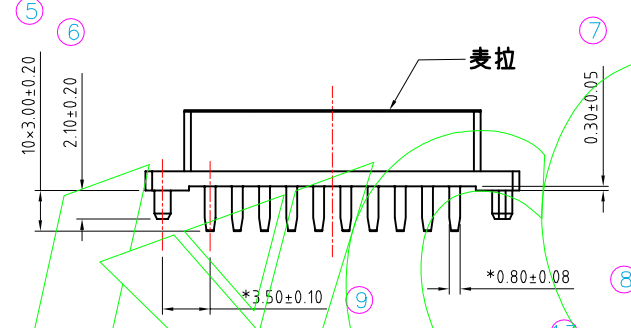
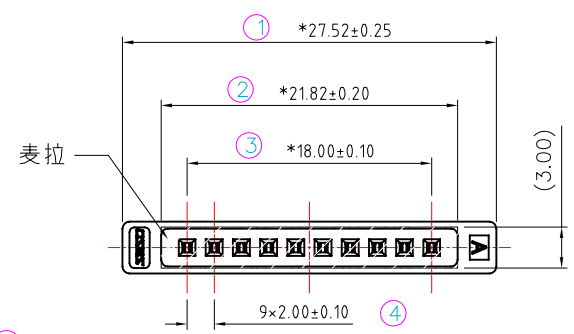

Recommended P.C.B  
Layout(T=1.6mm)  
(TOLERANCE:±0.05)

NO OF PINS PER ROW	Contact Plating	INSULATOR	PACKING
2-40P	Full of Gold	Semi-gold	A: PE Bag
	A0=0.8u"	B0=0.8U"	B: Tape & Reel
	A1=1u"	B1=1U"	C: Tube
	A2=1.5u"	B2=1.5U"	D: Tube+CAP
	A3=2u"	B3=2U"	E: Tray
	A4=3u"	B4=3U"	
	A5=5u"	B5=5U"	
	A6=10u"	B6=10U"	
	A7=15u"	B7=15U"	
	A8=20u"	B8=20U"	
	A9=30u"	B9=30U"	
	S1=Ordinary Tin Plated		
	S2=Matte Tin Plated		
	S3=Tin-plated High-temperature		

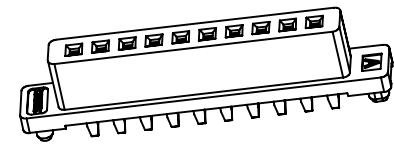

				OPERATION		SCALE		Fit		东莞市宇熙精密连接器有限公司 www.yxcon.com Dongguan Yuxi Electronic Co.,Ltd.	
				X.X	±0.20	UNIT		MM			
				X.XX	±0.15	SIZE	A4	DESIGN	李青杰2023.03.14	PART NO	F258-1110A2CSUB2T
				X.XXX	±0.08	SHEET	1/1	CHECK		TITLE	FH2.0*5.8特殊排母 1*10P 180度 DIP:3.0 带外柱 保持力1.5kg/ PW=3.8 U型 PA9T 镀全金接触点足1.5U 麦拉+600+40/透明卷
REV	DATE	SYMBOL	MODIFICATION DESCRIPTION			DIAM	TOL	PROJ.	APPROVE	Customer No.	